

# MARK-3® SERIES

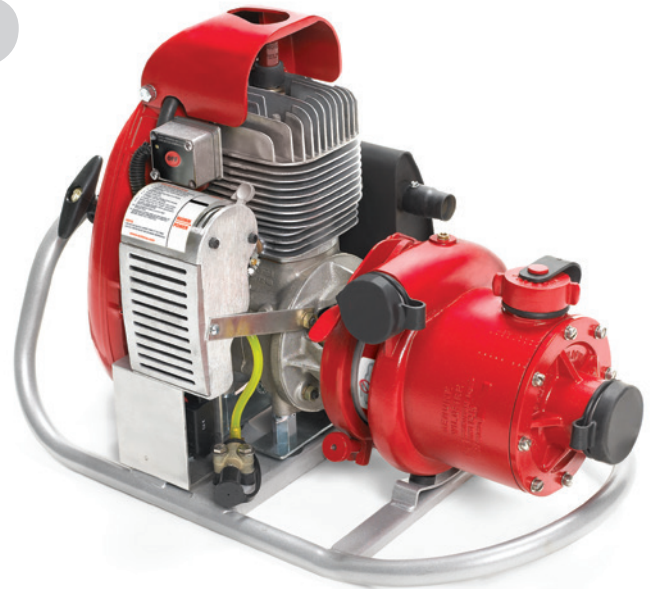

## MARK-3® PORTABLE

### PORTABLE LIGHTWEIGHT HIGH PRESSURE 4-STAGE FIRE PUMP

The **WATERAX MARK-3®** is an unparalleled combination of our **WATERAX** 185cc 2-stroke 10 hp engine matched with an innovative detachable, maintenance free 4-stage centrifugal pump end. This impressive workhorse can achieve pressures of up to 380 PSI (26.2 BAR) and flow rates reaching 98 GPM (371 L/Min).

Appreciated for its ability to maintain high pressure over extraordinary distances and elevation, the **MARK-3®** is designed to withstand the rigors and extreme conditions of wildland firefighting and is the most respected portable lightweight pump in the forest firefighting community.

**MARK-3®** meets or exceeds USDA Forest Service SPECIFICATION 5100-274 - Qualified under QPL Number 274-001  
Emergency rescue equipment - Exempt from emission standards under 40 CFR 1054.660.

#### Applications

- Attack line firefighting
- Long hose lay for remote watering during firefighting operations
- High elevation firefighting in mountainous areas
- Accuracy in flow trajectory when structure fire fighting
- Tandem pumping over long distances
- Parallel pumping for higher volumes

#### Features and Benefits

- Quick release clamp and swappable pump ends for minimal equipment downtime and inventory
- Sealed bearing to eliminate pump end greasing in the field
- Aluminium alloy pump components and anodized parts for lighter weight and greater resistance to corrosion
- Comprehensive user and service manuals

## SPECIFICATIONS

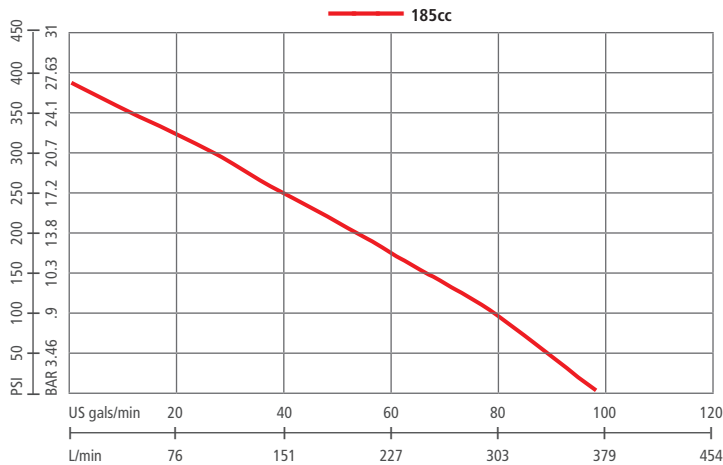

### Flow rate at specified pressure

Maximum Pressure : 380 PSI (26.2 bar)  
 Free flow : 98 US gals/min (371 L/min)  
 Maximum Head: 878' (268 m)

Flow Rate		Pressure		
US GPM	(LPM)	@	PSI	(BAR)
78	(295)	@	100	(6.9)
65	(246)	@	150	(10.3)
38	(144)	@	250	(17.2)

Engine: 185cc

### Engine Specifications

- Engine** WATERAX 185cc  
2-cycle, air-cooled, Nikasil cylinder
- Maximum power** 10 hp (7.5 kW)
- Displacement** 185 cc (11.29 cu in)
- Starting system** Recoil starter with backup manual rope starter
- Ignition** Ducati CDI
- Lubrication** Fuel Mix Ratio: 50:1 (gasoline to oil)
- Fuel type** Gasoline: unleaded 87 octane automotive gasoline (maximum 10% ethanol)  
Oil: 2-cycle mixing oil with API-TC, JASO FD and ISO-L-EGD certification (e.g.: Amsoil Saber® Professional Synthetic)
- Fuel consumption** 1.3 US gals/hr (4.9 L/hr)

### Pump Specifications

- Pump end** Detachable 4-stage centrifugal pump end  
Lightweight aluminum alloy pump components  
Anodized pump parts for corrosion resistance  
Foam compatible  
Stainless steel pump shaft  
Blister resistant mechanical rotary seal  
Maintenance-free sealed bearing  
Maximum allowable pump pressure: 600 psi (41.4 bar)  
Quick release lightweight pump clamp
- Connections** Suction: 2" (51 mm) NPSH  
Discharge: 1-1/2" (38 mm) NPSH  
Priming: 1-1/2" (38 mm) NPSH

### Standard Inclusions

- Digital Overspeed Switch
- Exclusive blister resistant mechanical rotary seal
- Maintenance free sealed bearing
- Powder coated carry frame
- Foam compatible
- Rubber protection caps with retainer
- Recoil starter
- US Forest Service approved spark arrestor
- Standard operating tool kit

### Options

- Fuel air transport tank 5.3 US gals (20L) FA-552Q
- Metal jerry can 5 US gals (19L) FA-352GSA-N
- Engine and pump repair tool kits R-900, R-952N, A-2356
- Backpack carrying frame C-7404

## TECHNICAL DRAWINGS

### MARK-3® PUMP CONFIGURATIONS

Model	Engine Fuel Connection		Fuel Tank		Fuel Line	Discharge Thread Protector	Suction Thread Protector	Decompression Switch	USFS Kit
	Mercury	SAE Flare 45	Air Transport FA-552Q	Metal Jerry Can FA-352GSA-N					
<b>MK3</b>	•								
<b>MK3-QS</b>	•				•	•	•		
<b>MK3-TQS</b>	•		•		•	•	•		
<b>MK3-D</b>	•							•	
<b>MK3-DTQS</b>	•		•		•	•	•	•	
<b>MK3-U</b> (NSN# 4320-01-495-3633)		•			•	•	•		
<b>MK3-UT</b>		•		•	•	•	•		
<b>MK3-UTK</b> (NSN# 4320-00-890-5879)		•		•	•	•	•		•

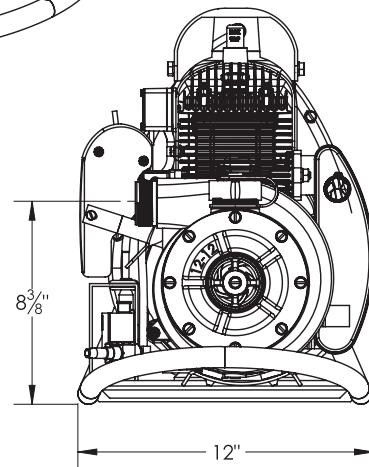
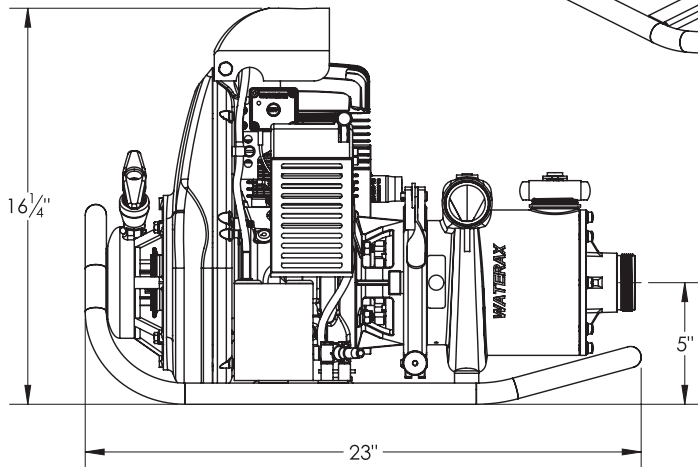
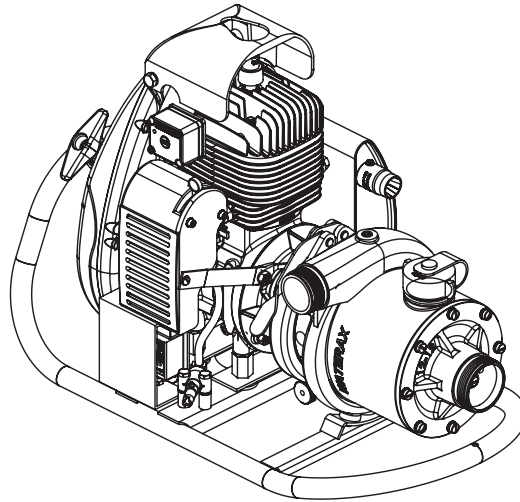

Length 23" (58 cm)

Width 12" (31 cm)

Height 16-1/4" (41 cm)

Weight 58.3 lbs (26.4 kg)



**WATERAX Inc.**  
6635 Henri-Bourassa W.  
Montreal, QC H4R 1E1

**TF 855-616-1818**

**T** 514-637-1818

**F** 514-637-3985

info@waterax.com  
www.waterax.com

Distributed by:

All information contained in this document including drawings is proprietary to *WATERAX* and may not be copied, reproduced or used in whole or in part without our prior written permission. The information in this document is subject to change without notice. Model displayed with multiple options. Weight and dimensions are approximated and may vary depending on options.